



Energy requirement data for food processing

Louis Lagrange





Roadmap

- **What was developed - helicopterise**
- **How was it constructed – data architecture**
- **Can we trust the data - compare literature**
- **How can the data be applied:**



Roadmap

- **What was developed - helicopterise**
- **How was it constructed – data architecture**
- **Can we trust the data - compare literature**
- **How can the data be applied:**
 - Benchmarking (?)
 - Identify real energy requirements (pareto)
 - Identify Demand Side Management opportunities
 - Identify Research and Development opportunities

What was developed - helicopterise

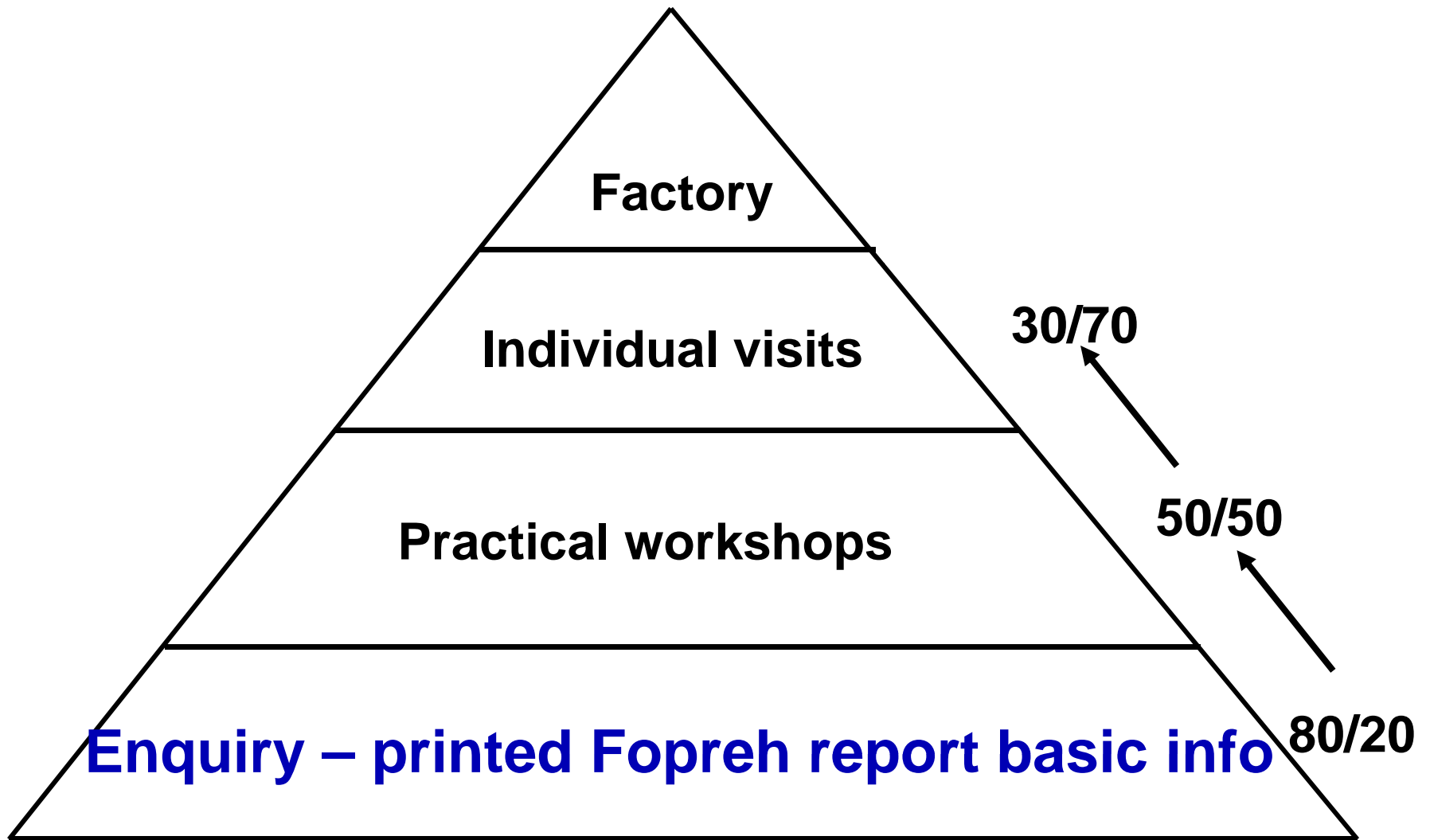

What was developed - helicopterise

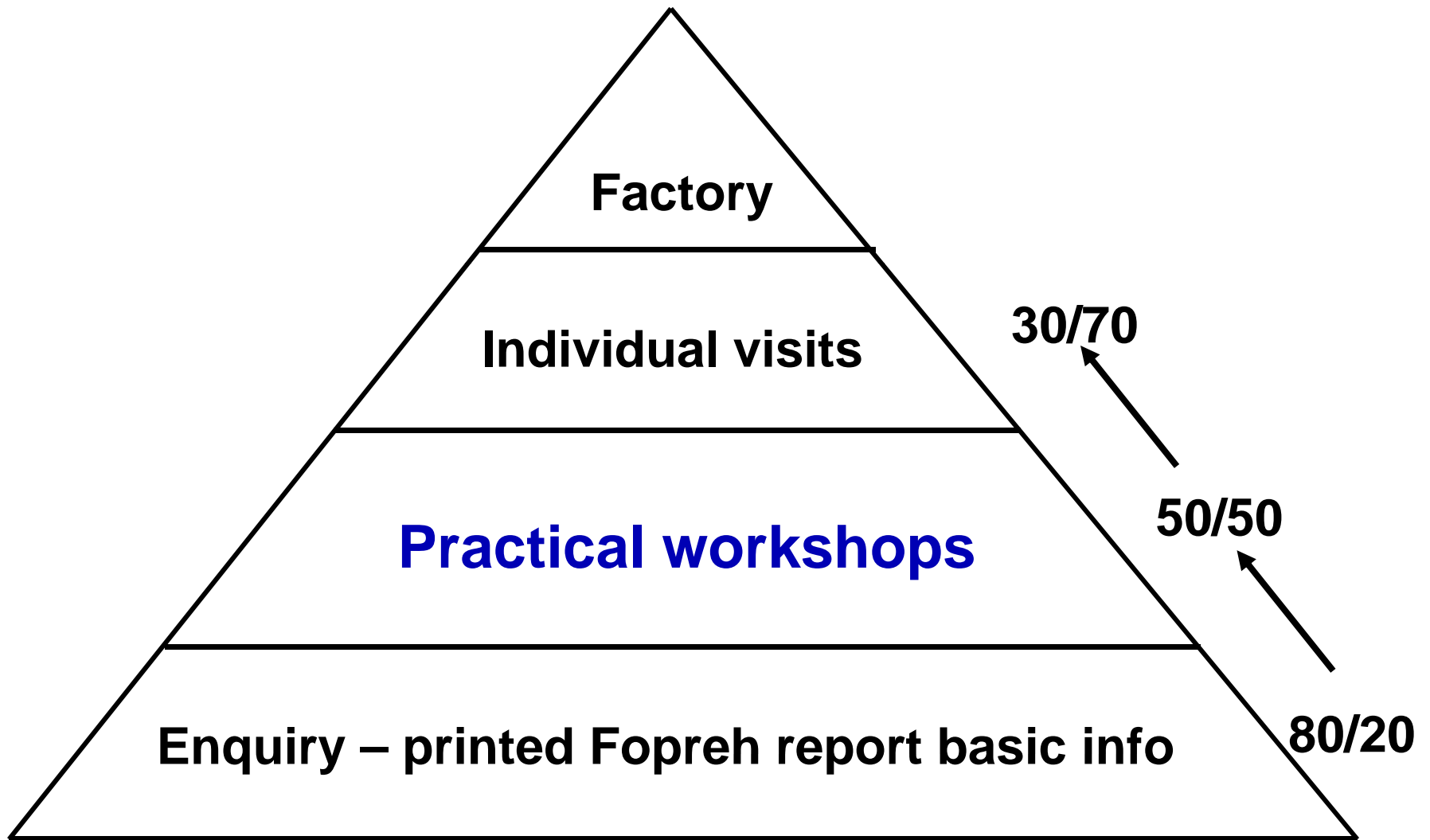

What was developed - helicopterise

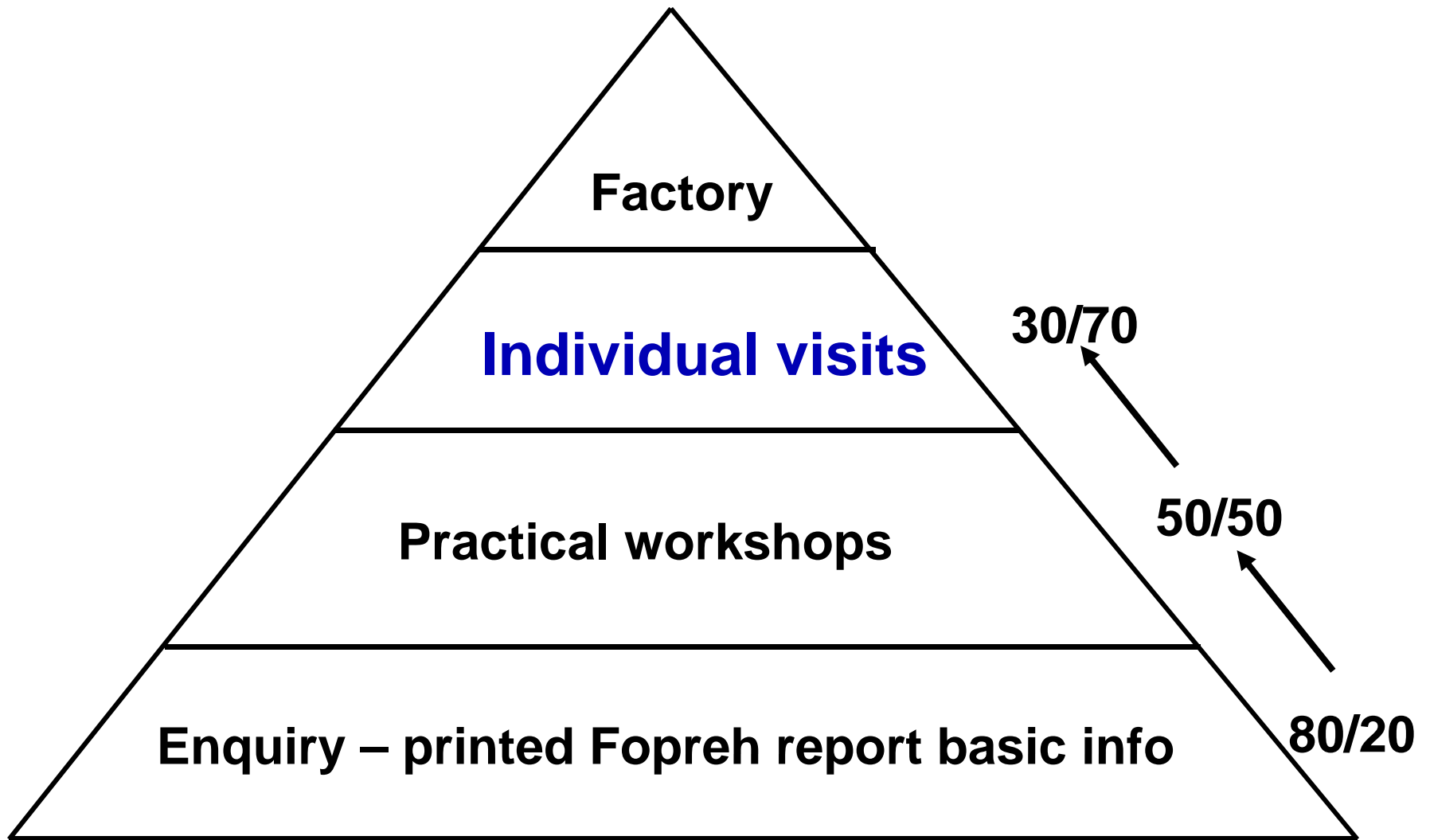

What was developed - helicopterise

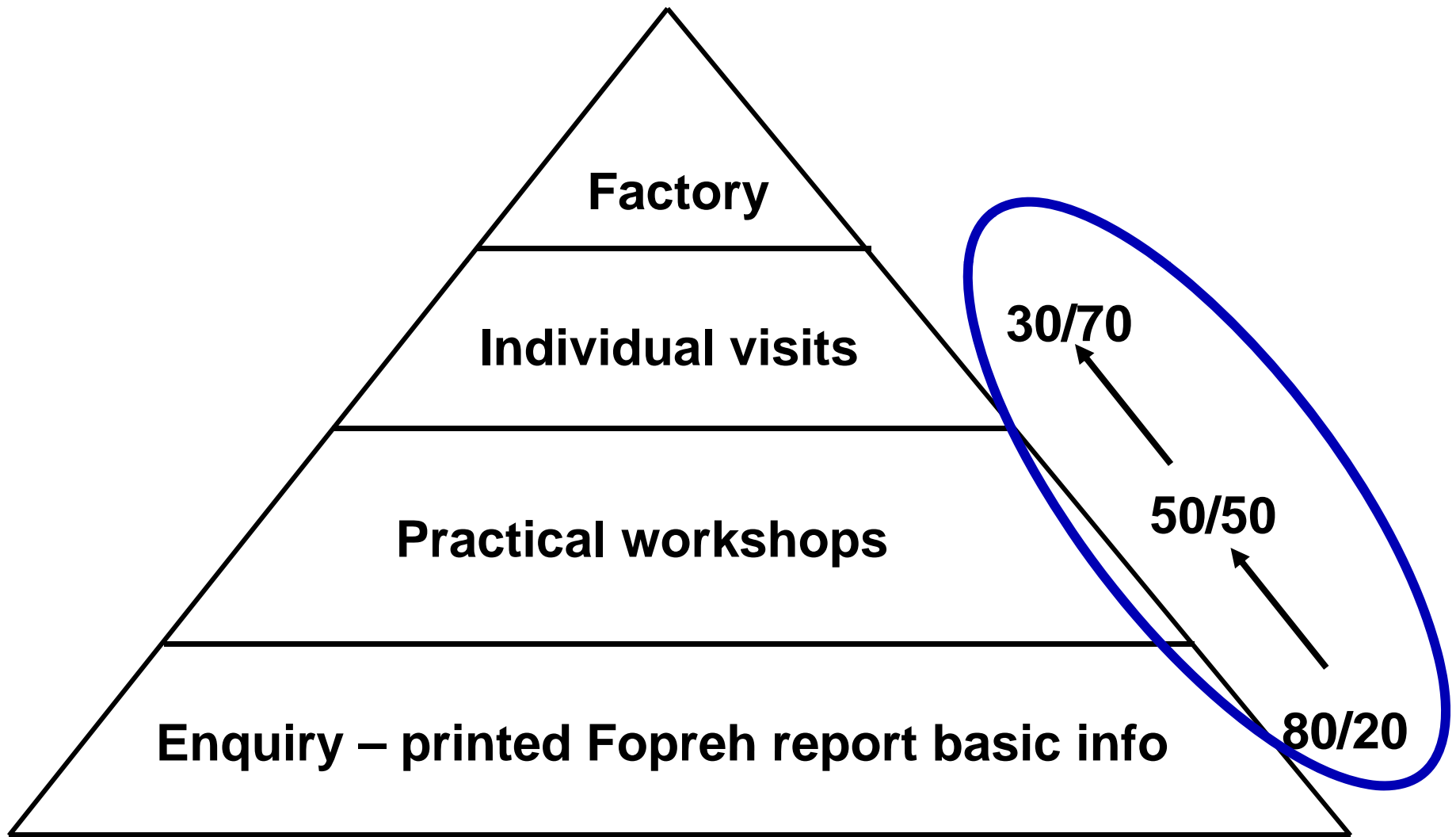

What was developed - helicopterise

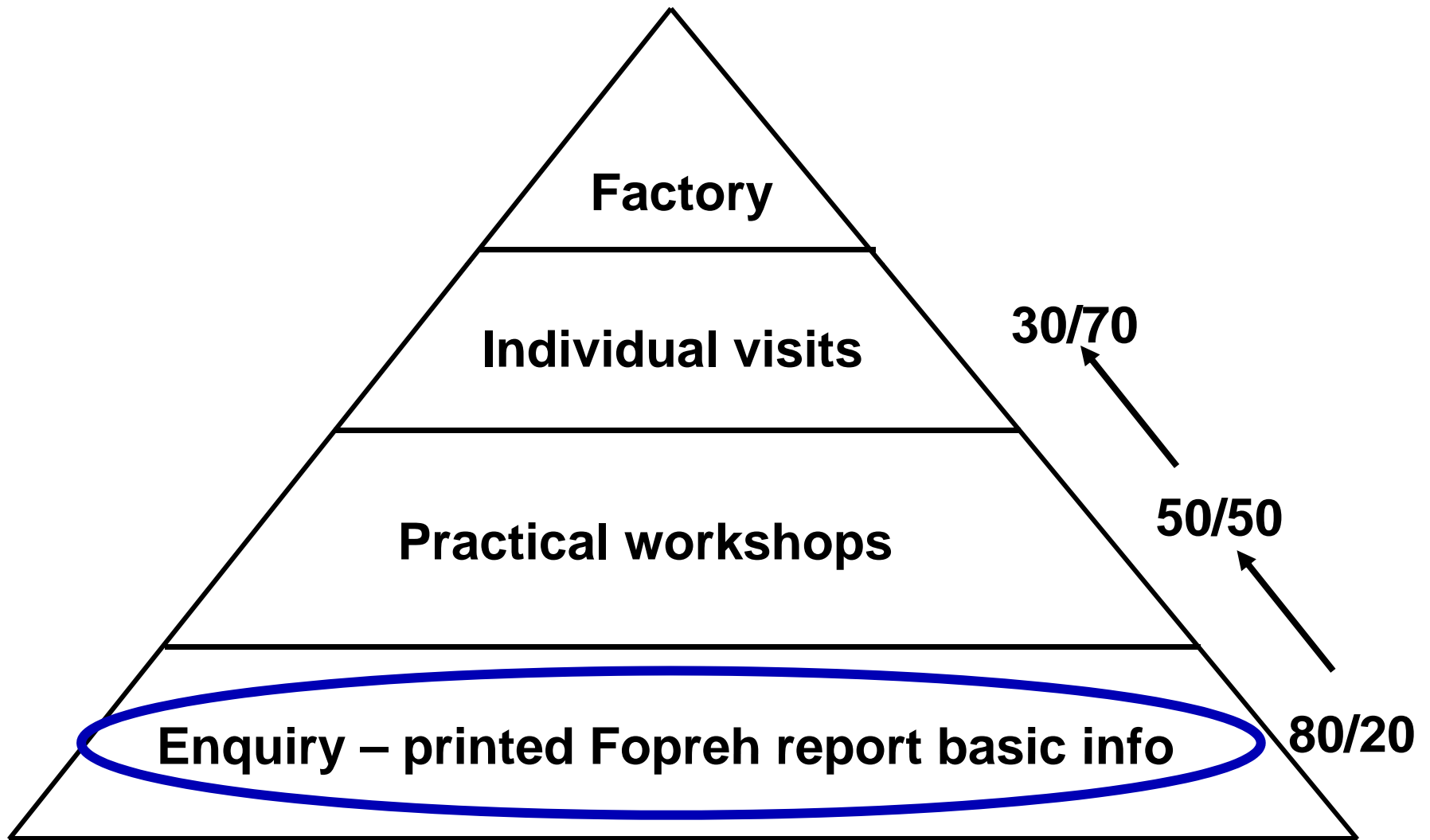



Fopreh report

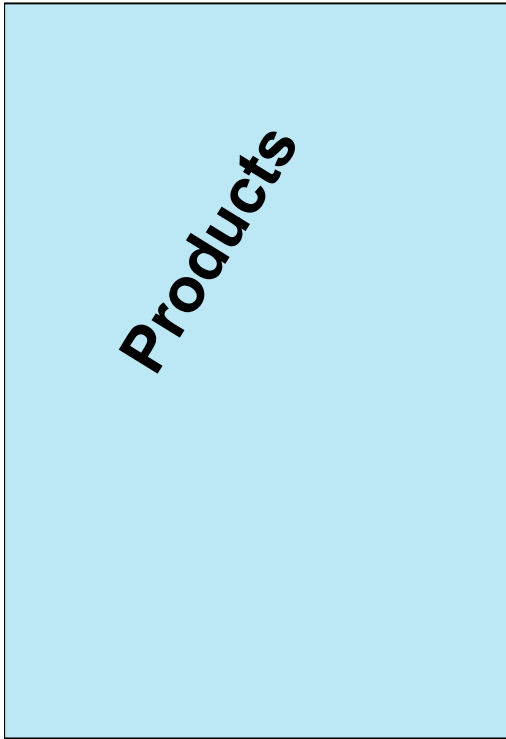



Fopreh report



Products



Flow Diagram



Fopreh report

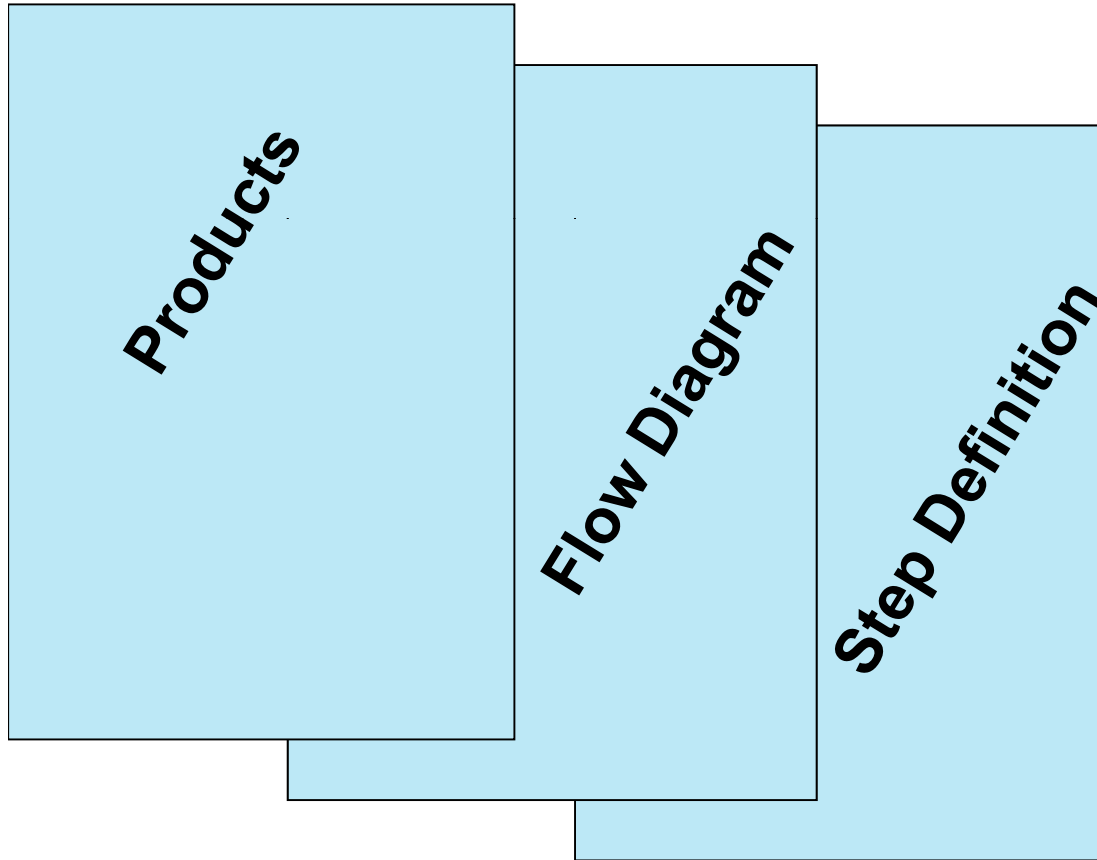



Fopreh report

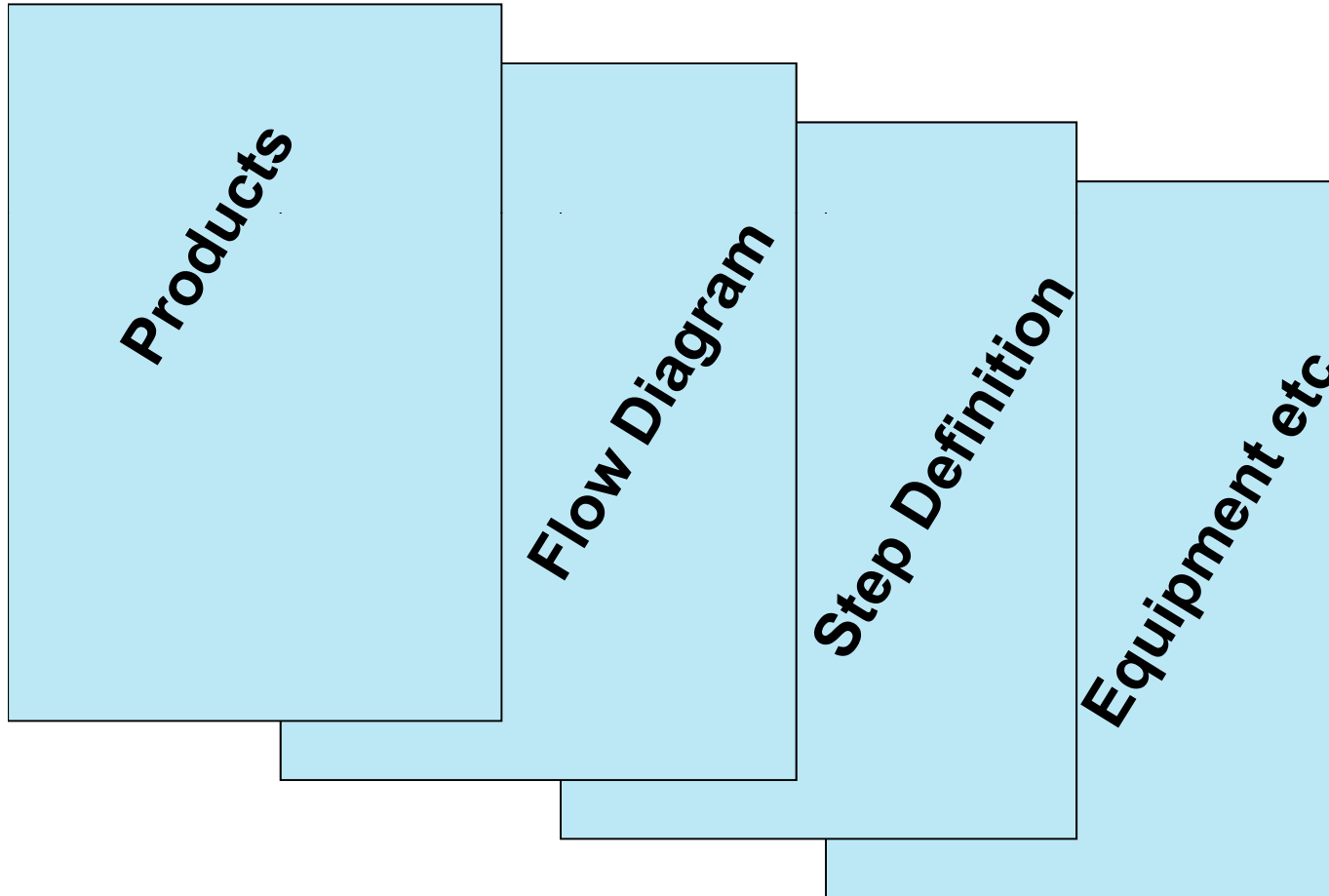



Fopreh report

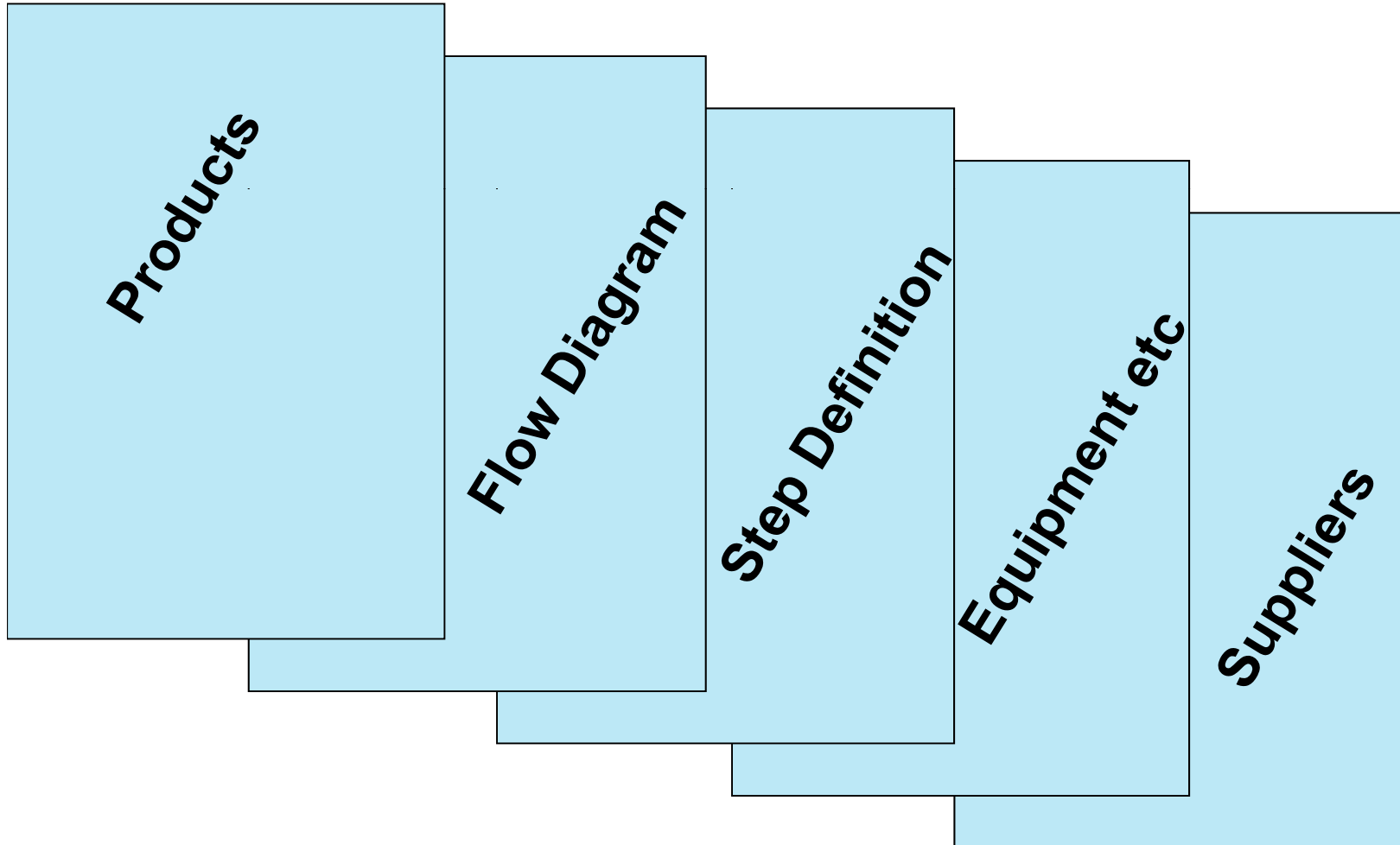



Fopreh report

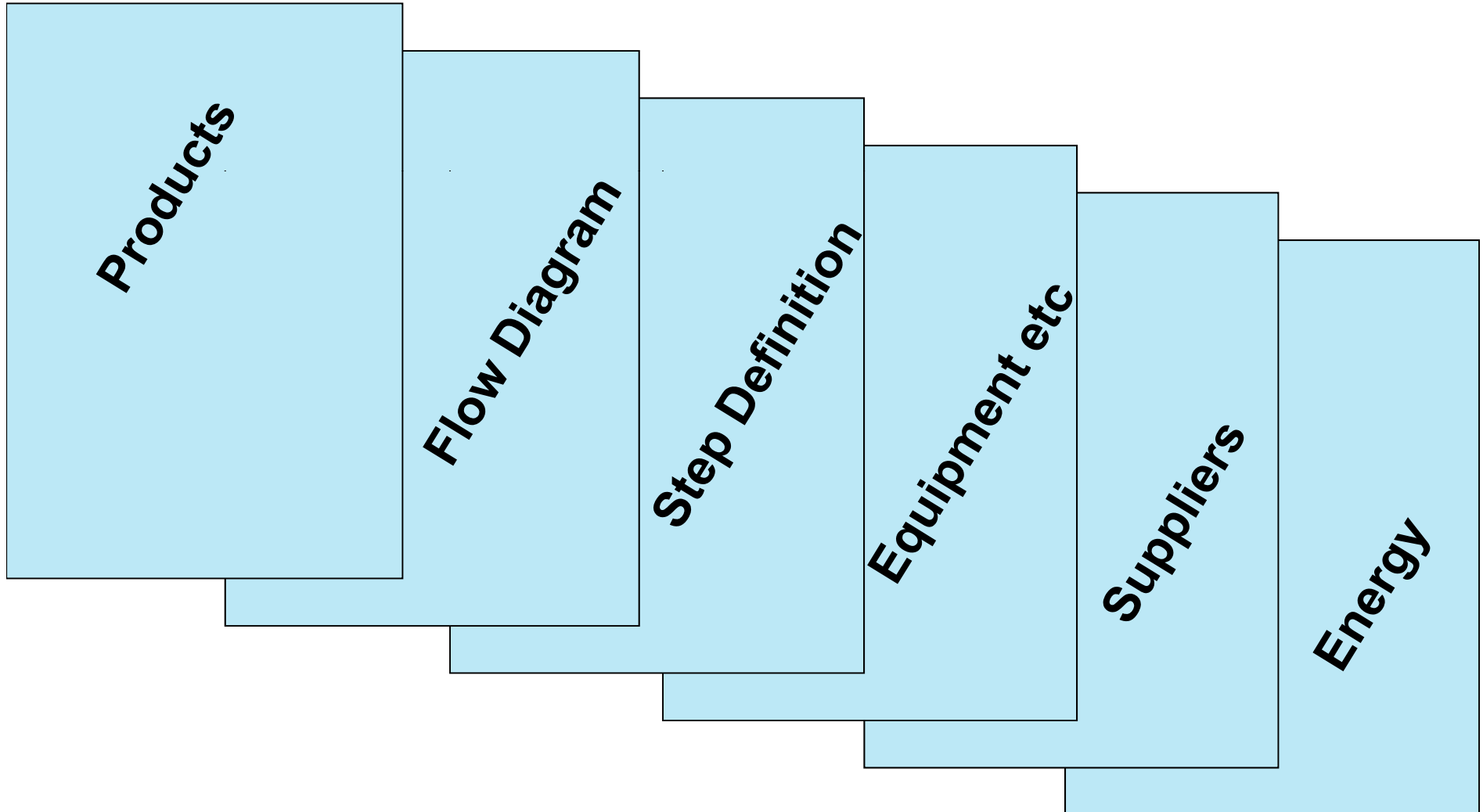



Fopreh report

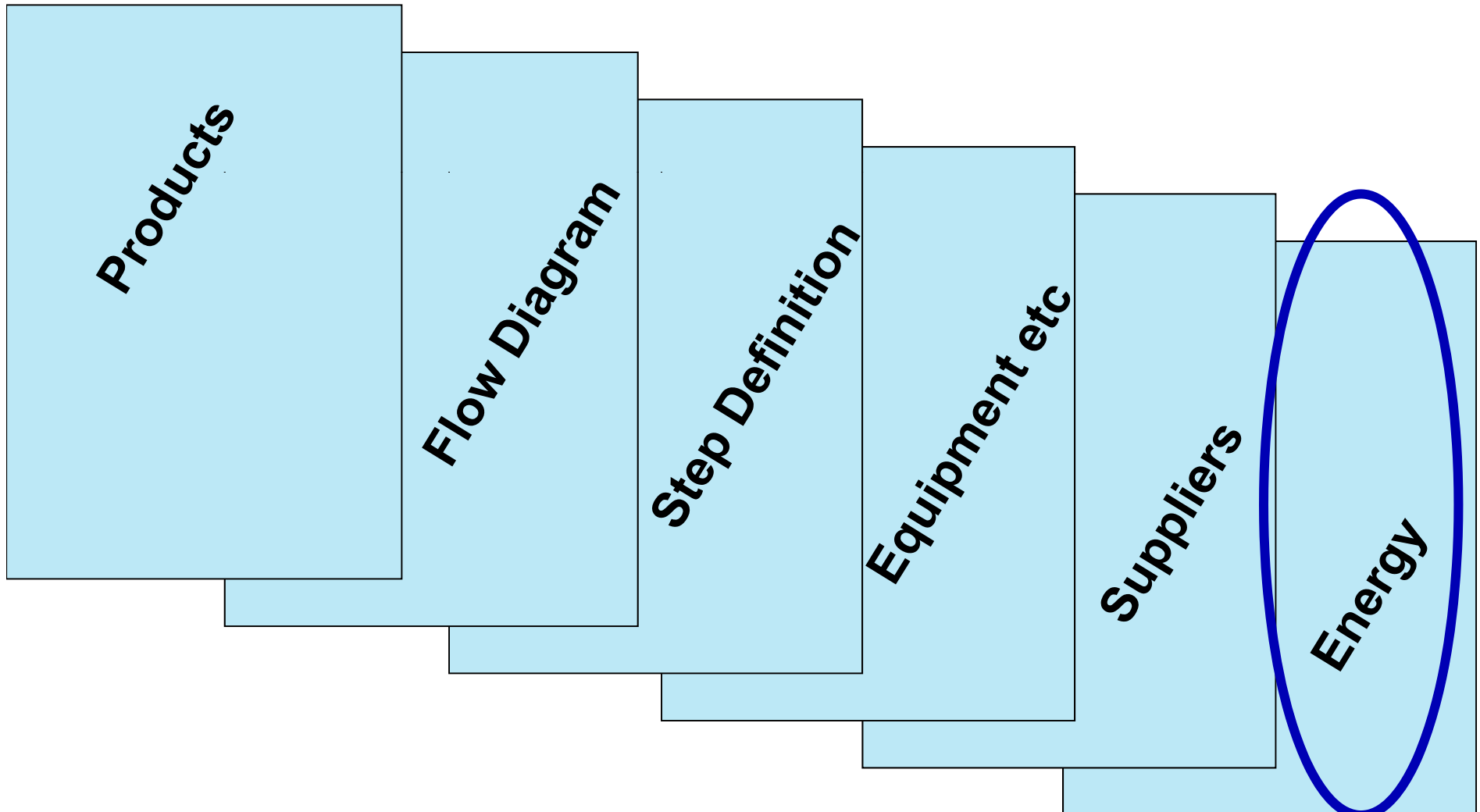



Roadmap

- What was developed - helicopterise
- **How was it constructed – data architecture**
- Can we trust the data - compare literature
- How can the data be applied:

Construction – data architecture

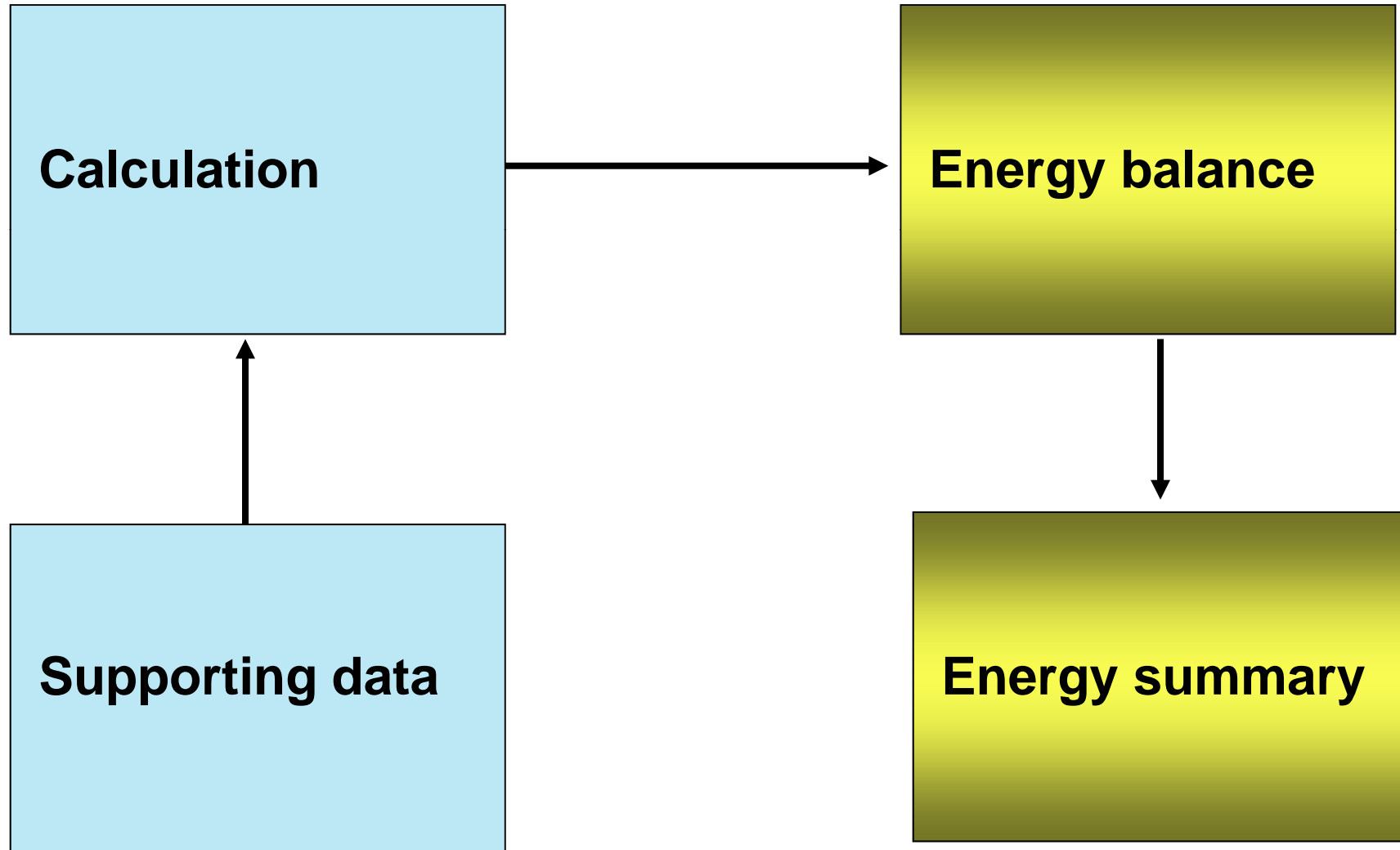

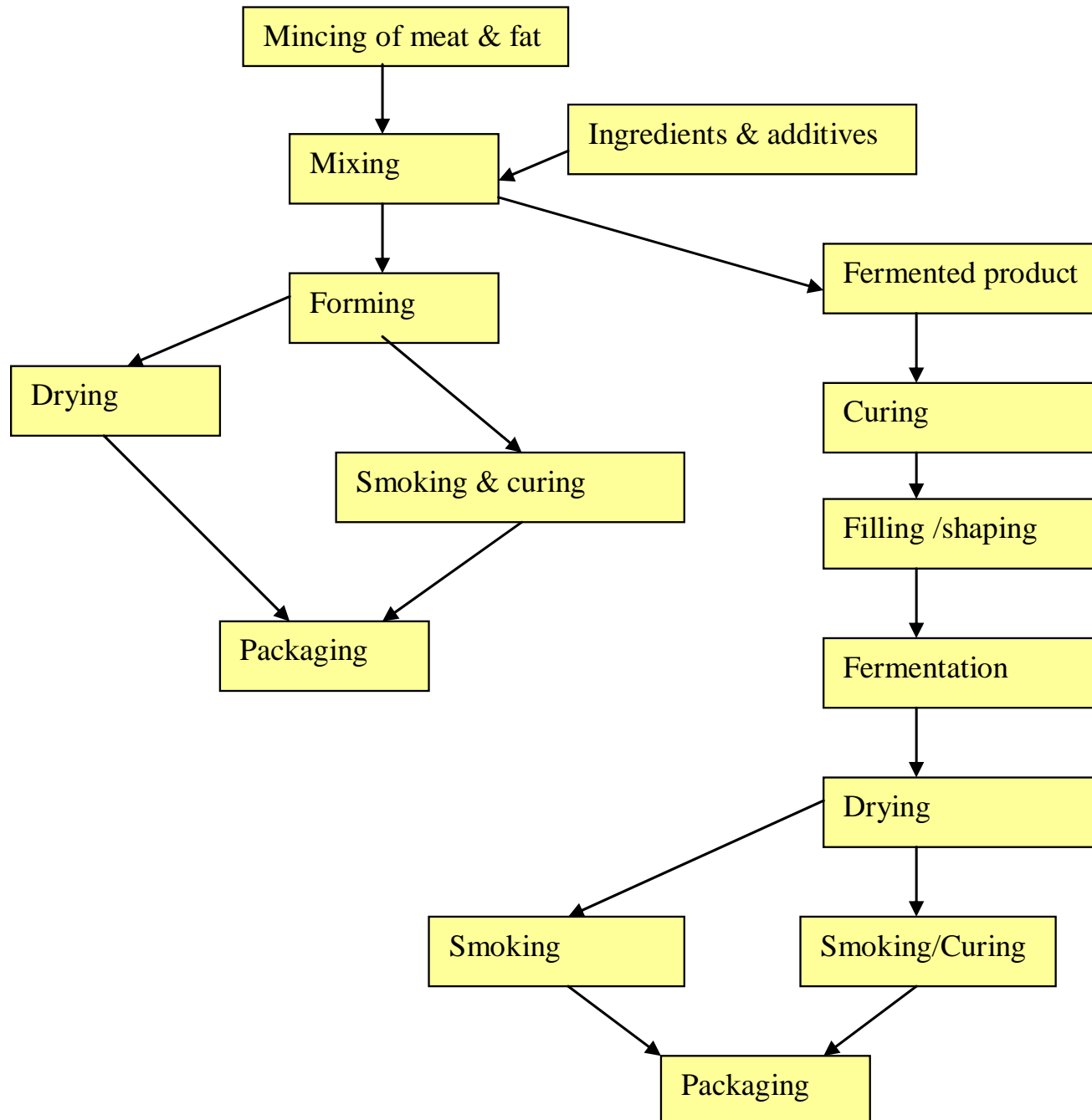

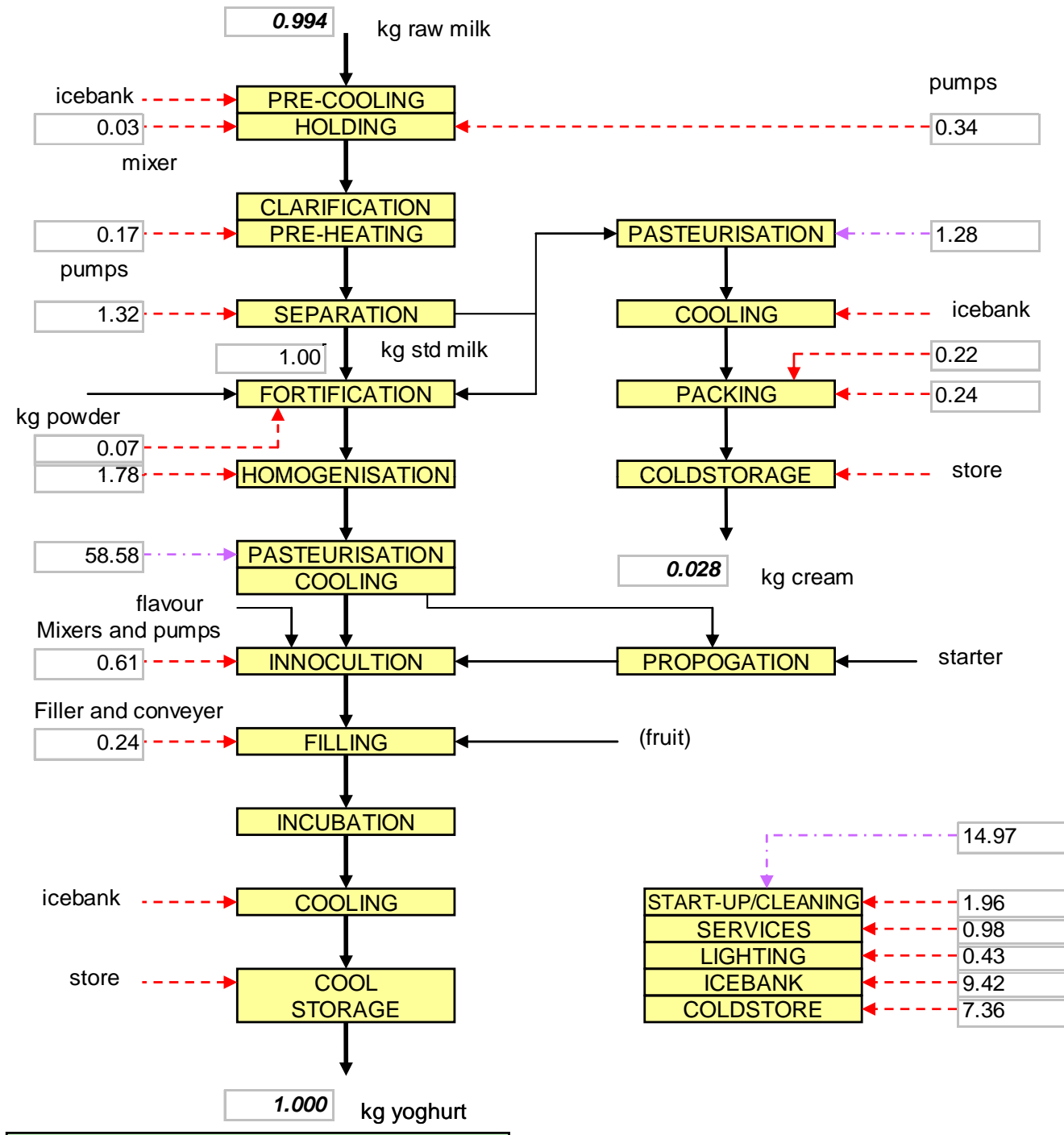

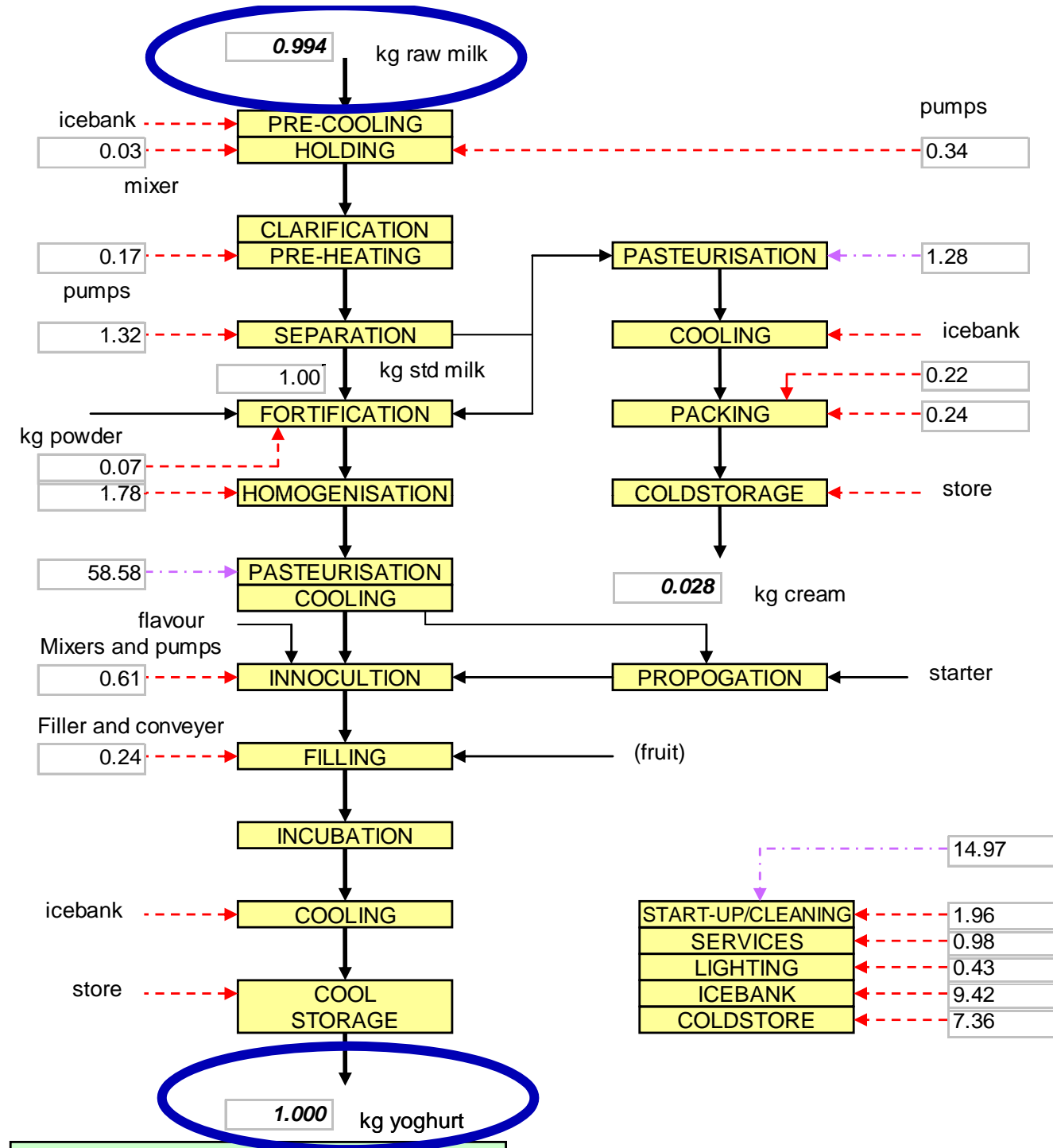

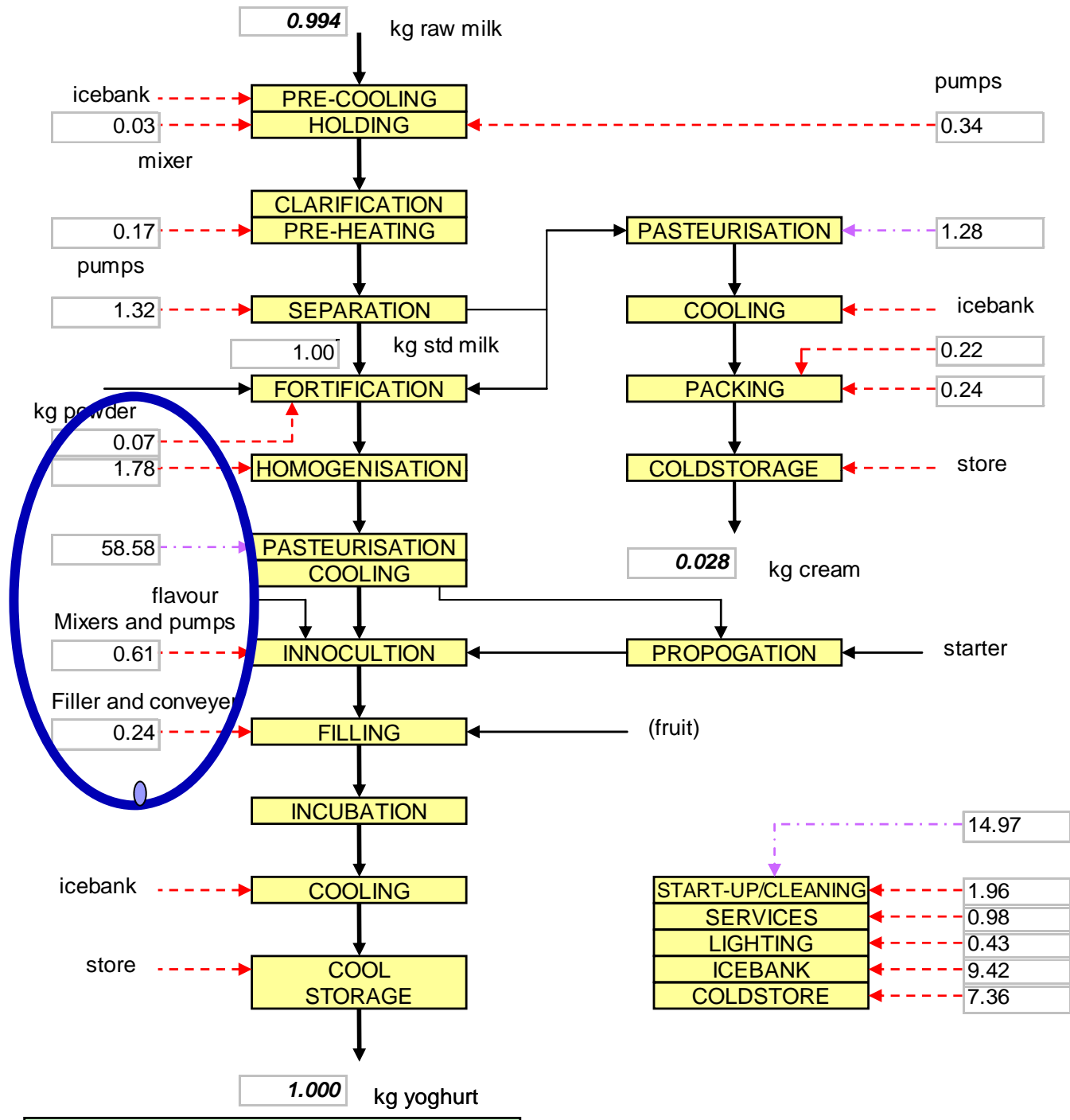

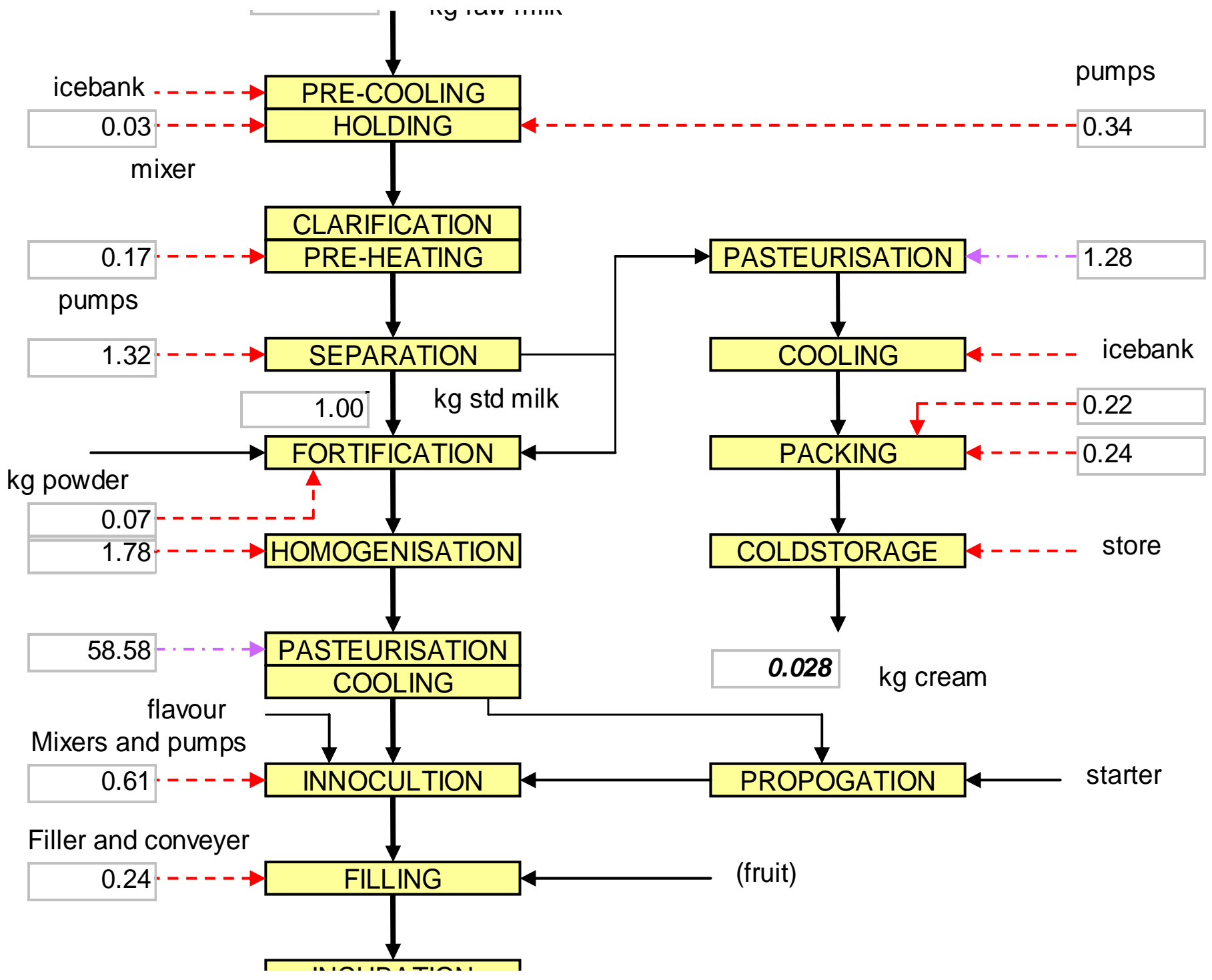

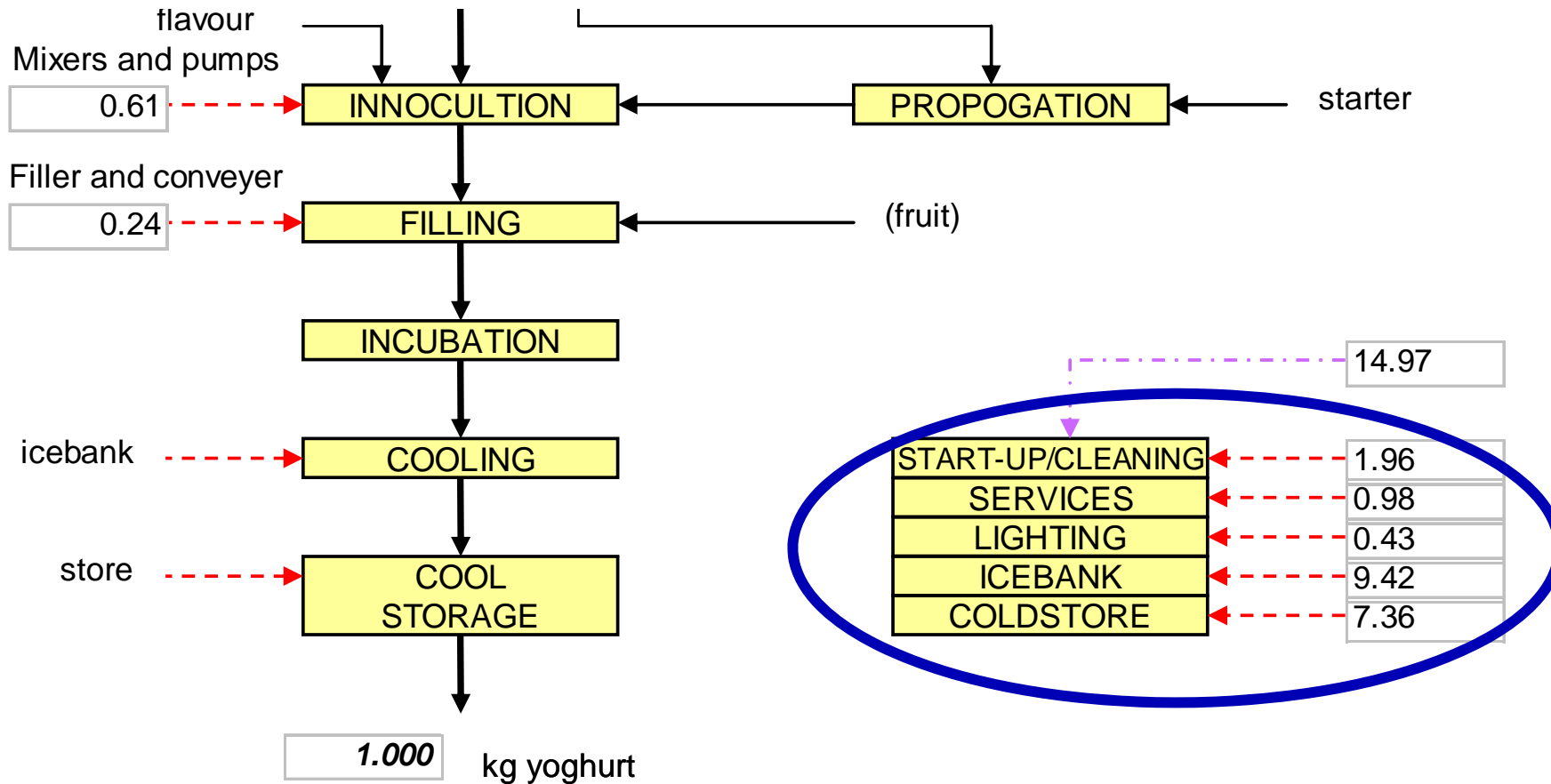

Energy per kg of final product (kJ)	
Electrical	73.05
Other	217.24
Total	<u>290.29</u>
Energy per kg of feed (kJ)	
Electrical	218.65
Other	218.65
Total	<u>292.17</u>
Installed Power (kW)	150.89

ENERGY DIAGRAM

PRODUCT: Set Yoghurt (1) (Full Fat)

QUALIFIER: Medium Dairy (20 000 l milk/day)

ASSUMPTIONS:

1. Milk is received cool (7 deg)
2. Clarification by filter/strainer

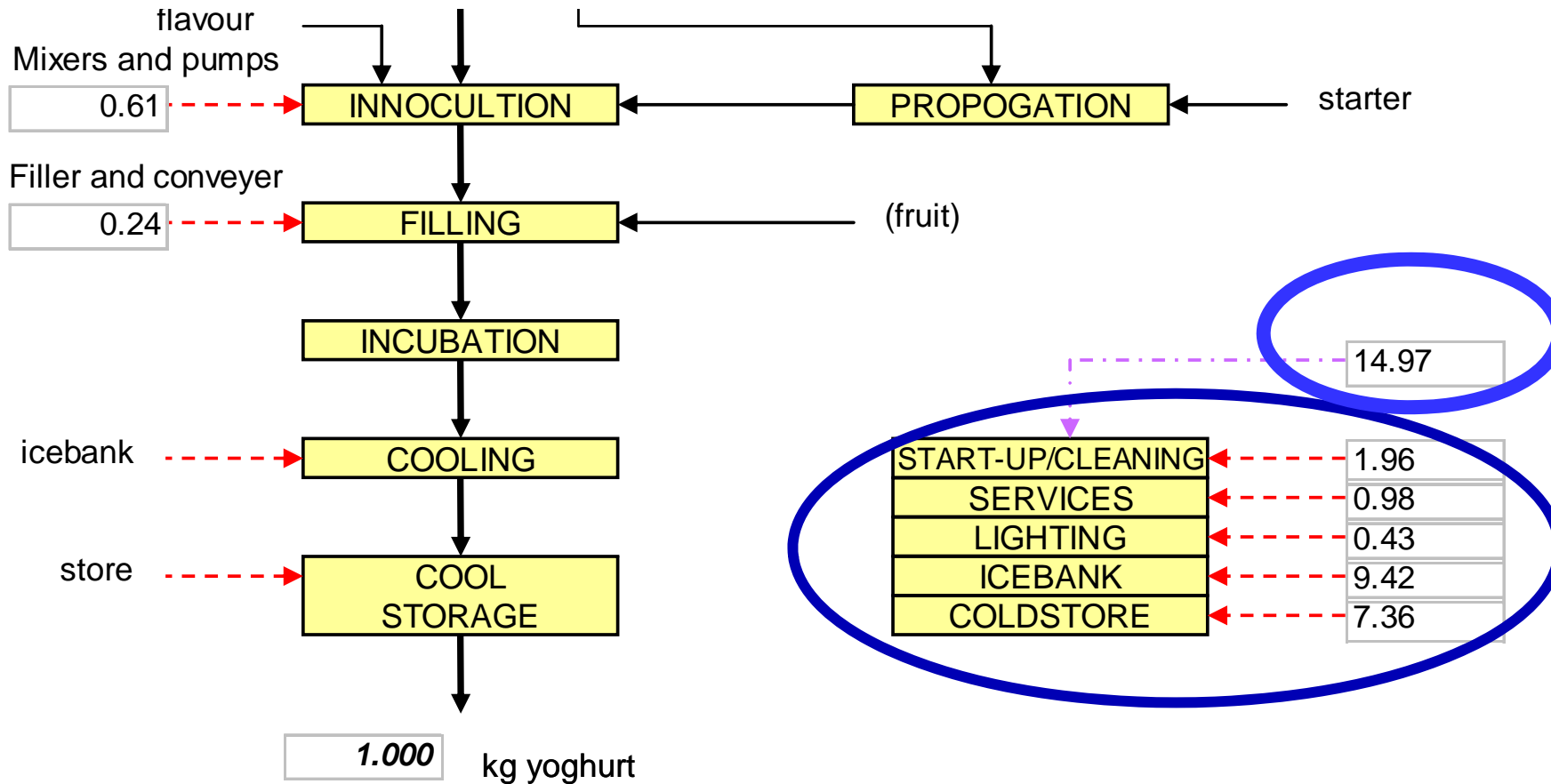

Energy per kg of final product (kJ)	
Electrical	73.05
Other	217.24
Total	<u>290.29</u>
Energy per kg of feed (kJ)	
Electrical	218.65
Other	218.65
Total	<u>292.17</u>
Installed Power (kW)	<u>150.89</u>

ENERGY DIAGRAM

PRODUCT: Set Yoghurt (1) (Full Fat)

QUALIFIER: Medium Dairy (20 000 l milk/day)

ASSUMPTIONS:

1. Milk is received cool (7 deg)
2. Clarification by filter/strainer

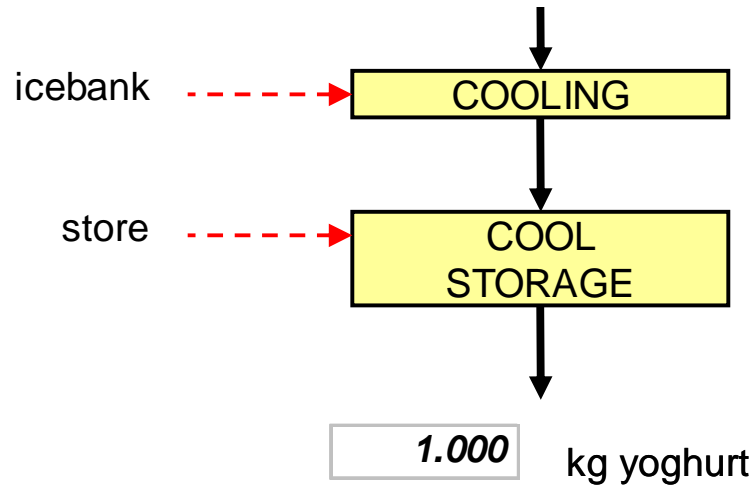

Energy per kg of final product (kJ)	
Electrical	73.05
Other	217.24
Total	<u>290.29</u>
Energy per kg of feed (kJ)	
Electrical	218.65
Other	218.65
Total	<u>292.17</u>
Installed Power (kW)	<u>150.89</u>

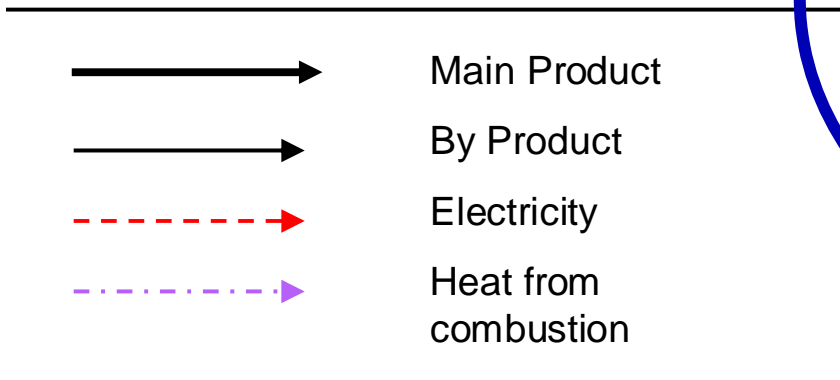

ENERGY DIAGRAM

PRODUCT: Set Yoghurt (1) (Full Fat)

QUALIFIER: Medium Dairy (20 000 l milk/day)

ASSUMPTIONS:

1. Milk is received cool (7 deg)
2. Clarification by filter/strainer
3. Cream is batch pasteurised and packed
4. Negligible Product losses
5. Composition. Fat 3.5% , SNF content 11.6% (addition of approx 3% Powder), Fruit etc 0

ENERGY INPUTS IN % OF TOTAL REQUIREMENTS

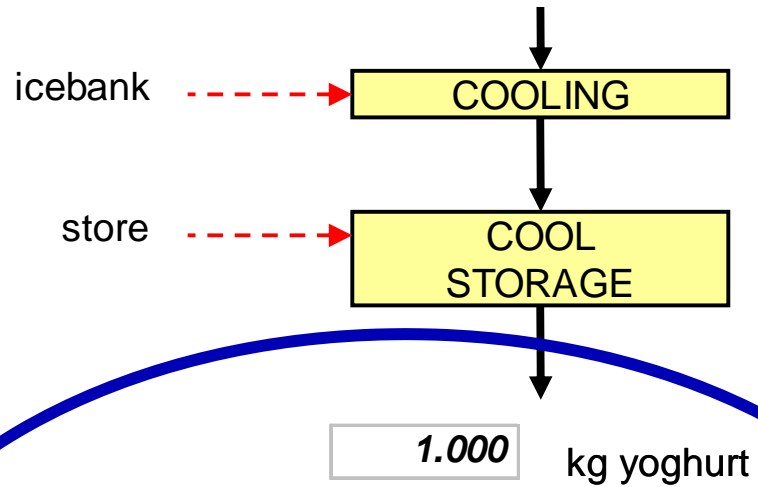

START-UP/CLEANING	1.96
SERVICES	0.98
LIGHTING	0.43
ICEBANK	9.42
COLDSTORE	7.36

Energy per kg of final product (kJ)	
Electrical	73.05
Other	217.24
Total	<u>290.29</u>
Energy per kg of feed (kJ)	
Electrical	218.65
Other	218.65
Total	<u>292.17</u>
Installed Power (kW)	150.89

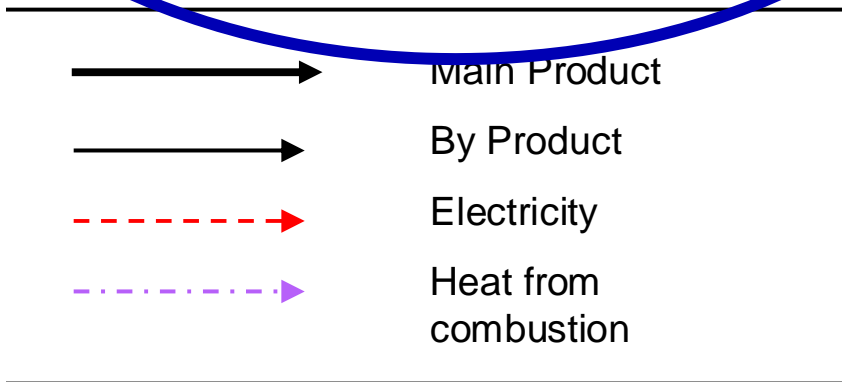

ENERGY DIAGRAM

PRODUCT: Set Yoghurt (1) (Full Fat)

QUALIFIER: Medium Dairy (20 000 l milk/day)

ASSUMPTIONS:

1. Milk is received cool (7 deg)
2. Clarification by filter/strainer
3. Cream is batch pasteurised and packed
4. Negligible Product losses
5. Composition. Fat 3.5% , SNF content 11.6% (addition of approx 3% Powder), Fruit etc 0

ENERGY INPUTS IN % OF TOTAL REQUIREMENTS

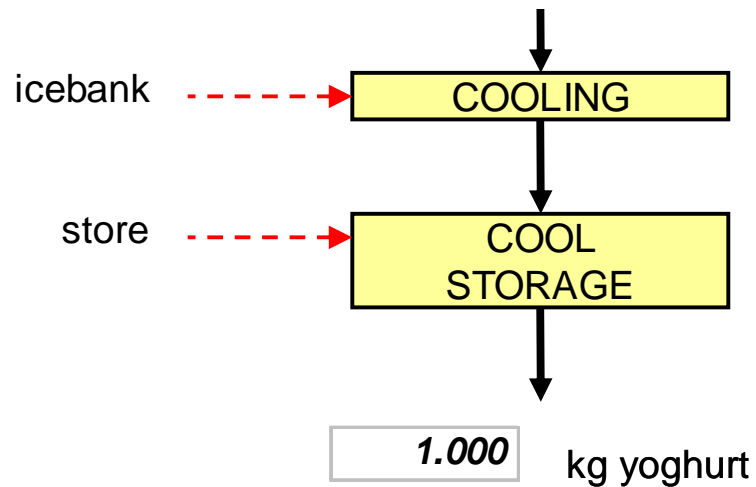

Energy per kg of final product (kJ)	
Electrical	73.05
Other	217.24
Total	<u>290.29</u>
Energy per kg of feed (kJ)	
Electrical	218.65
Other	218.65
Total	<u>292.17</u>
Installed Power (kW)	<u>150.89</u>

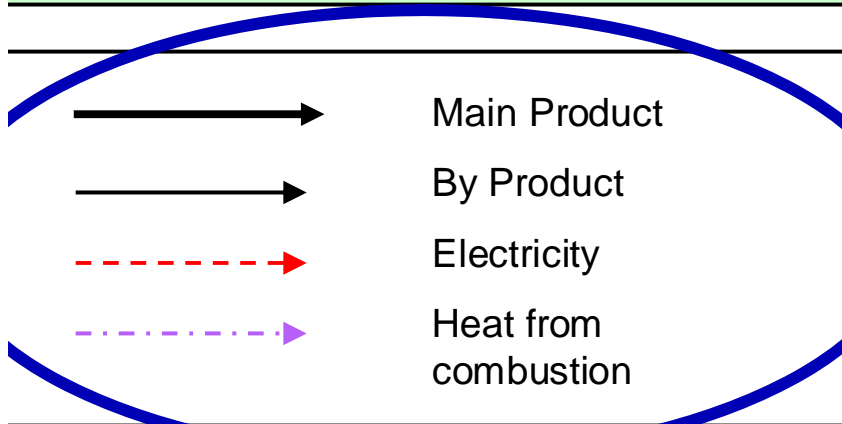

ENERGY DIAGRAM

PRODUCT: Set Yoghurt (1) (Full Fat)

QUALIFIER: Medium Dairy (20 000 l milk/day)

ASSUMPTIONS:

1. Milk is received cool (7 deg)
2. Clarification by filter/strainer
3. Cream is batch pasteurised and packed
4. Negligible Product losses
5. Composition. Fat 3.5% , SNF content 11.6% (addition of approx 3% Powder), Fruit etc 0

ENERGY INPUTS IN % OF TOTAL REQUIREMENTS

Construction – energy summary

■ Energy Input in kJ/kg

1. ENERGY USAGE (kJ/kg Yoghurt)			
	Electrical	Other	Total
Process	14.56	173.80	188.36
Other	58.48	43.45	101.93
Total	73.05	217.24	290.29

Construction – energy summary

■ Energy Input in kJ/kg

1. ENERGY USAGE (kJ/kg Yoghurt)			
	Electrical	Other	Total
Process	14.56	173.80	188.36
Other	58.48	43.45	101.93
Total	73.05	217.24	290.29

Construction – energy summary

■ Energy Input in kJ/kg

1. ENERGY USAGE (kJ/kg Yoghurt)			
	Electrical	Other	Total
Process	14.56	173.80	188.36
Other	58.48	43.45	101.93
Total	73.05	217.24	290.29

Construction – energy summary

■ Energy Input in kJ/kg

1. ENERGY USAGE (kJ/kg Yoghurt)			
	Electrical	Other	Total
Process	14.56	173.80	188.36
Other	58.48	43.45	101.93
Total	73.05	217.24	290.29

■ Installed electric power (excluding boiler)

2. INSTALLED ELECTRIC POWER (EXCLUDING BOILER)		
Plant Capacity (l/day raw milk)	20000	
Total installed Power (kW)	150.89	
Motors (kW)	138.89	
Heating (kW)	5.00	
Lighting (kW)	7.00	



Roadmap

- What was developed - helicopterise
- How was it constructed – data architecture
- **Can we trust the data - compare literature**
- How can the data be applied:



Comparison with literature

- USA
- Canada
- Australia
- Europe
- Scandinavia
- Netherlands
- Britain
- Kenya
- Finland
- Norway

Comparison with literature (MJ/kg)

Milk Benchmark kJ/kg product			
	International	Fopreh	
	Ave	Low	High
Milk	0.22	0.18	0.78
Butter	2.5	2.5	3.5
Cheese	1.8	1.1	9.1
Concentrated milk	1.8	2.2	2.7

Comparison with literature (MJ/kg)

Milk Benchmark kJ/kg product				
	International		Fopreh	
	Ave		Low	High
Milk	0.22		0.18	0.78
Butter	2.5		2.5	3.5
Cheese	1.8		1.1	9.1
Concentrated milk	1.8		2.2	2.7

Comparison with literature (MJ/kg)

Milk Benchmark kJ/kg product				
	International		Fopreh	
	Ave		Low	High
Milk	0.22		0.18	0.78
Butter	2.5		2.5	3.5
Cheese	1.8		1.1	9.1
Concentrated milk	1.8		2.2	2.7

Fruit / Vegetables	2.415		1.287	2.768
--------------------	-------	--	-------	-------



Comparison with literature (kWh/kg)

Milk Benchmark kWh/kg raw milk				
	International		Fopreh	
	Low	High	Low	High
Milk + Cultured	0.1	0.2	0.05	0.22
Cheese	0.2	0.3	0.07	0.26
Powder	0.3	0.4	0.3	0.45

Comparison with literature (kWh/kg)

Milk Benchmark kWh/kg raw milk				
	International		Fopreh	
	Low	High	Low	High
Milk + Cultured	0.1	0.2	0.05	0.22
Cheese	0.2	0.3	0.07	0.26
Powder	0.3	0.4	0.3	0.45



Roadmap

- What was developed - helicopterise
- How was it constructed – data architecture
- Can we trust the data - compare literature
- **How can the data be applied:**
 - Benchmarking, market size, Carbon emissions
 - Identify real energy requirements (pareto)
 - Identify Demand Side Management opportunities
 - Identify Research and Development opportunities



3 M Opportunities

- **M**ine the data to enrich ourselves
- **M**assage the data to release some stress
- **M**anipulate the data to show what we want,
never mind the real story

Opportunities

Group	Product	Size	Elec	Other	Total	%elec
DAIRY	Butter continuous process		1770	1714	3484	51
Concentrated	Butter traditional process (2)	large	2343	909	3251	72
		small	2465	0	2465	100
	Butteroil direct process		1459	1134	2593	56
	Butteroil semi-direct process		1010	412	1422	71
	Cream pasteurised (2)	35% fat	957	417	1373	70
		20% fat	624	230	853	73
	Cream sterilised		356	487	844	42
	Cream UHT		365	416	781	47
	Milk condensed		838	1945	2783	30
	Milk evaporated		736	1508	2244	33
Cultured	Amazi (2)	Large	61	168	228	27
		Small	784	0	784	100
	Buttermilk cultured (2)	Large	124	137	261	48
		Small	683	594	1277	53

Opportunities

Group	Product	Size	Elec	Other	Total	%elec
DAIRY	Butter continuous process		1770	1714	3484	51
Concentrated	Butter traditional process (2)	large	2343	909	3251	72
		small	2465	0	2465	100
	Butteroil direct process		1459	1134	2593	56
	Butteroil semi-direct process		1010	412	1422	71
	Cream pasteurised (2)	35% fat	957	417	1373	70
		20% fat	624	230	853	73
	Cream sterilised		356	487	844	42
	Cream UHT		365	416	781	47
	Milk condensed		838	1945	2783	30
	Milk evaporated		736	1508	2244	33
Cultured	Amazi (2)	Large	61	168	228	27
		Small	784	0	784	100
	Buttermilk cultured (2)	Large	124	137	261	48
		Small	683	594	1277	53

Opportunities

Group	Product	Size	Elec	Other	Total	%elec
DAIRY	Butter continuous process		1770	1714	3484	51
Concentrated	Butter traditional process (2)	large	2343	909	3251	72
		small	2465	0	2465	100
	Butteroil direct process		1459	1134	2593	56
	Butteroil semi-direct process		1010	412	1422	71
	Cream pasteurised (2)	35% fat	957	417	1373	70
		20% fat	624	230	853	73
	Cream sterilised		356	487	844	42
	Cream UHT		365	416	781	47
	Milk condensed		838	1945	2783	30
	Milk evaporated		736	1508	2244	33
Cultured	Amazi (2)	Large	61	168	228	27
		Small	784	0	784	100
	Buttermilk cultured (2)	Large	124	137	261	48
		Small	683	594	1277	53

Opportunities

Group	Product	Size	Elec	Other	Total	%elec
DAIRY	Butter continuous process		1770	1714	3484	51
Concentrated	Butter traditional process (2)	large	2343	909	3251	72
		small	2465	0	2465	100
	Butteroil direct process		1459	1134	2593	56
	Butteroil semi-direct process		1010	412	1422	71
	Cream pasteurised (2)	35% fat	957	417	1373	70
		20% fat	624	230	853	73
	Cream sterilised		356	487	844	42
	Cream UHT		365	416	781	47
	Milk condensed		838	1945	2783	30
	Milk evaporated		736	1508	2244	33
Cultured	Amazi (2)	Large	61	168	228	27
		Small	784	0	784	100
	Buttermilk cultured (2)	Large	124	137	261	48
		Small	683	594	1277	53

Opportunities

Group	Product	Size	Elec	Other	Total	%elec
DAIRY	Butter continuous process		1770	1714	3484	51
Concentrated	Butter traditional process (2)	large	2343	909	3251	72
		small	2465	0	2465	100
	Butteroil direct process		1459	1134	2593	56
	Butteroil semi-direct process		1010	412	1422	71
	Cream pasteurised (2)	35% fat	957	417	1373	70
		20% fat	624	230	853	73
	Cream sterilised		356	487	844	42
	Cream UHT		365	416	781	47
	Milk condensed		838	1945	2783	30
	Milk evaporated		736	1508	2244	33
Cultured	Amazi (2)	Large	61	168	228	27
		Small	784	0	784	100
	Buttermilk cultured (2)	Large	124	137	261	48
		Small	683	594	1277	53



Opportunities

- Mine the data for trends:
 - 79 % of energy comes from fossil fuels
 - 21 % energy comes from electricity
 - Cultured dairy 35 – 78 % from electricity
 - Large scale factories use only 80 % to as low as 24 % of the energy vs small scale
 - Small Scale factories 100 % electricity
 - Many many opportunities in small scale factories



Opportunities

- Mine the data for trends:
 - 79 % of energy comes from fossil fuels
 - 21 % energy comes from electricity
 - Cultured dairy 35 – 78 % from electricity
 - Large scale factories use only 80 % to as low as 24 % of the energy vs small scale
 - Small Scale factories 100 % electricity
 - Many many opportunities in small scale factories



Opportunities

- Mine the data for trends:
 - 79 % of energy comes from fossil fuels
 - 21 % energy comes from electricity
 - Cultured dairy 35 – 78 % from electricity
 - Large scale factories use only 80 % to as low as 24 % of the energy of small scale
 - Small Scale factories 100 % electricity
 - Many many opportunities in small scale factories



Opportunities

- Mine the data for trends:
 - 79 % of energy comes from fossil fuels
 - 21 % energy comes from electricity
 - Cultured dairy 35 – 78 % from electricity
 - Large scale factories use only 80 % to as low as 24 % of the energy vs small scale
 - Small Scale factories 100 % electricity
 - Many many opportunities in small scale factories



Opportunities

- Calculate Carbon Emissions:
 - Input from electricity - 333 g CO₂/MJ
 - Input from coal - 187 g CO₂/MJ
 - Input from furnace oil/diesel - 77 g CO₂/MJ
- Dairy Amazi = 52 g CO₂/kg

Opportunities DSM

Process step	kJ/kg	%	Load shifting
Mincing	0.48	0.0	
Comminution		0.0	
Emulsification	30.57	2.1	Yes, shifting in operating hours required
Mixing		0.0	
Cooling		0.0	See HVAC
Stuffing	5.38	0.4	
Tempering		0.0	
Smoking	187.2	12.7	See HVAC
Cooking	72	4.9	
Packaging	11.52	0.8	
Cooling		0.0	See HVAC
Storage		0.0	
Cleaning	1008	68.3	Yes, shifting in operating hours required
Lighting	15.8	1.1	
HVAC	144.54	9.8	Yes, fairly large capital may be required to change HVAC for shift
Icemaking		0.0	
Totals	1475.49	100	

Meat

Process step	Meat russians		Meat liver spread		Meat frankfurters		Meat french polony	
	kJ/ kg	%	kJ/ kg	%	kJ/ kg	%	kJ/ kg	%
Trimming/ curing	N/A		0.00	0.00	N/A			0.00
Mincing	0.25	0.67	3.19	0.92	0.30	0.76	0.29	0.73
Comminution, emulsify& mix	16.18	43.49	158.16	45.44	12.80	32.53	11.66	29.40
Cooling	0.00	0.00	N/A		N/A		N/A	
Stuffing	2.85	7.66	41.75	11.99	3.38	8.59	3.08	7.77
Tempering	0.00	0.00	N/A		0.00	0.00	N/A	
Smoking	12.38	32.28	N/A		15.82	40.20	N/A	
Cooking	4.76	12.80	145.00	41.65	6.08	15.45	24.63	62.10
Shaping	N/A		N/A		N/A		N/A	
Crumbing	N/A		N/A		N/A		N/A	
Flash frying	N/A		N/A		N/A		N/A	
Cooling and tempering	N/A		N/A		N/A		N/A	
Packaging	0.78	2.10	N/A		0.97	2.47	N/A	
Cooling	0.00	0.00	0.00	0.00	0.00	0.00	0.00	0.00
Storage	0.00	0.00	0.00	0.00	0.00	0.00	0.00	0.00
Total	37.20	100.00	348.10	100.00	39.35	100.00	39.66	100.00

Meat

Process step	Meat russians		Meat liver spread		Meat frankfurters		Meat french polony	
	kJ/ kg	%	kJ/ kg	%	kJ/ kg	%	kJ/ kg	%
Trimming/ curing	N/A		0.00	0.00	N/A			0.00
Mincing	0.25	0.67	3.19	0.92	0.30	0.76	0.29	0.73
Comminution, emulsify & mix	16.18	43.49	158.16	45.44	12.80	32.53	11.66	29.40
Cooling	0.00	0.00	N/A		N/A		N/A	
Stuffing	2.85	7.66	41.75	11.99	3.38	8.59	3.08	7.77
Tempering	0.00	0.00	N/A		0.00	0.00	N/A	
Smoking	12.38	33.28	N/A		15.82	40.20	N/A	
Cooking	4.76	12.80	145.00	41.65	6.08	15.45	24.63	62.10
Shaping	N/A		N/A		N/A		N/A	
Crumbing	N/A		N/A		N/A		N/A	
Flash frying	N/A		N/A		N/A		N/A	
Cooling and tempering	N/A		N/A		N/A		N/A	
Packaging	0.78	2.10	N/A		0.97	2.47	N/A	
Cooling	0.00	0.00	0.00	0.00	0.00	0.00	0.00	0.00
Storage	0.00	0.00	0.00	0.00	0.00	0.00	0.00	0.00
Total	37.20	100.00	348.10	100.00	39.35	100.00	39.66	100.00





Summary – food processing energy data

- Data is **available (218 products, 309 SS)**
- Data is **useable**
- Data can be **applied** to provide decision making information